



OLOFSTRÖM

UNIFEEDER



PRESS AUTOMATION

MAGNETIC BELT CONVEYOR

- Simple and solid construction.
- Many year's experience from industrial controllers and press automation contributes to user friendliness and high productivity.

PDS

Functional Principle

The Magnetic Belt Conveyor is a device for transportation of blanks.

Handling Capability:

Feed direction	min 100 mm max 2500 mm.
Width	min 100 mm. max 4500 mm
Weight. (panel). Speed	max 60 kg. ca 17 stroke/min.
Weight:	800 kg

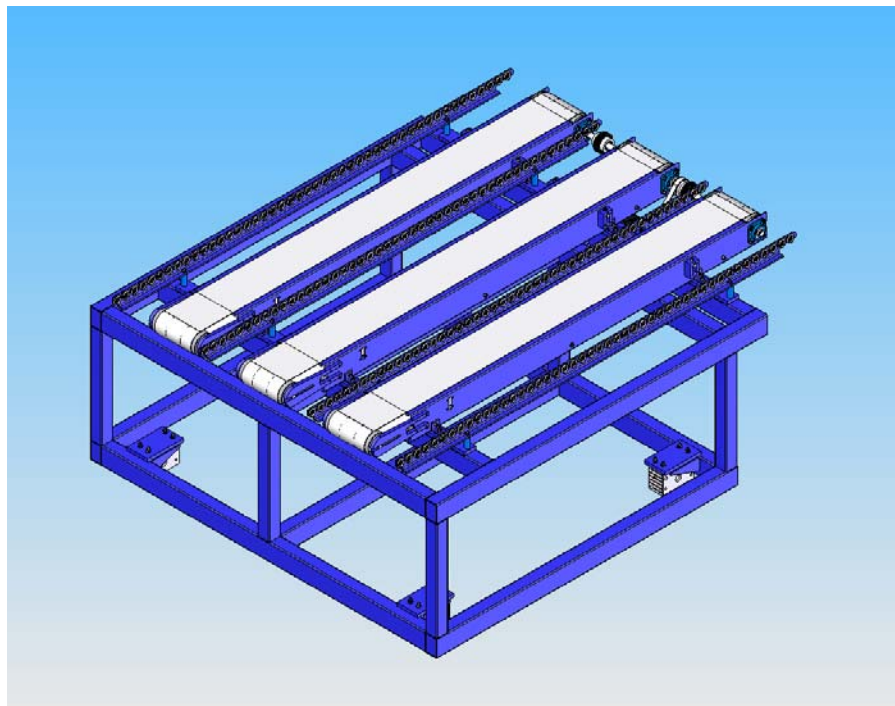

Data for speed is stored in the control system.

Edition 1.2 eng