

MC CLAMP

Mekanisk spännare

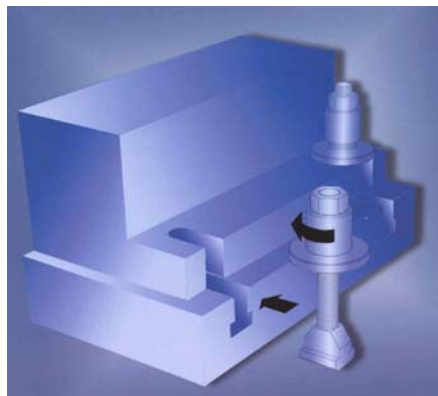

- Snabb verktygsinspänning
- Utväxling med självlåsande mekanism för snabb och vibrationssäker fastspänning
- 1 muttervarv = 4 - 5,5 mm slag
- Allt i ett, komplett enhet med smidd bult
- Kundanpassad höjd
- Slag 15-35 mm, beroende av typ
- Lätt att förvara intill hållare (MC-H tillbehör)



MC-Clamp i fastspänt läge

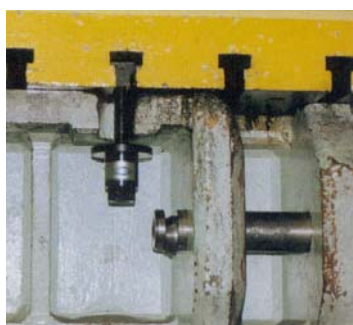

MC-Clamp, övre verktyg, ej fastspänt läge



MC-Clamp för nedre verktyg, i fastspänt läge

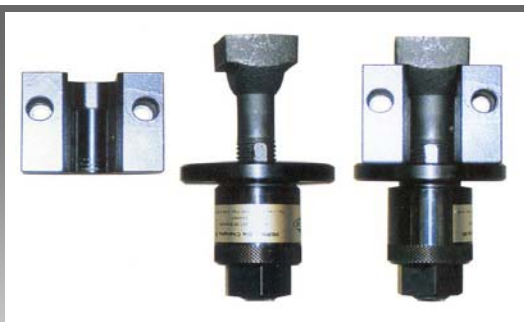

MC-H hållare för MC-Clamp



Spärrnyckel för MC-Clamp

H10-46 635mm / 2,30 kg
H8-36 500mm / 1,16 kg
H6-30 400mm / 0,75 kg
H4-24 305mm / 0,50 kg

MC CLAMP

Mekanisk spännare

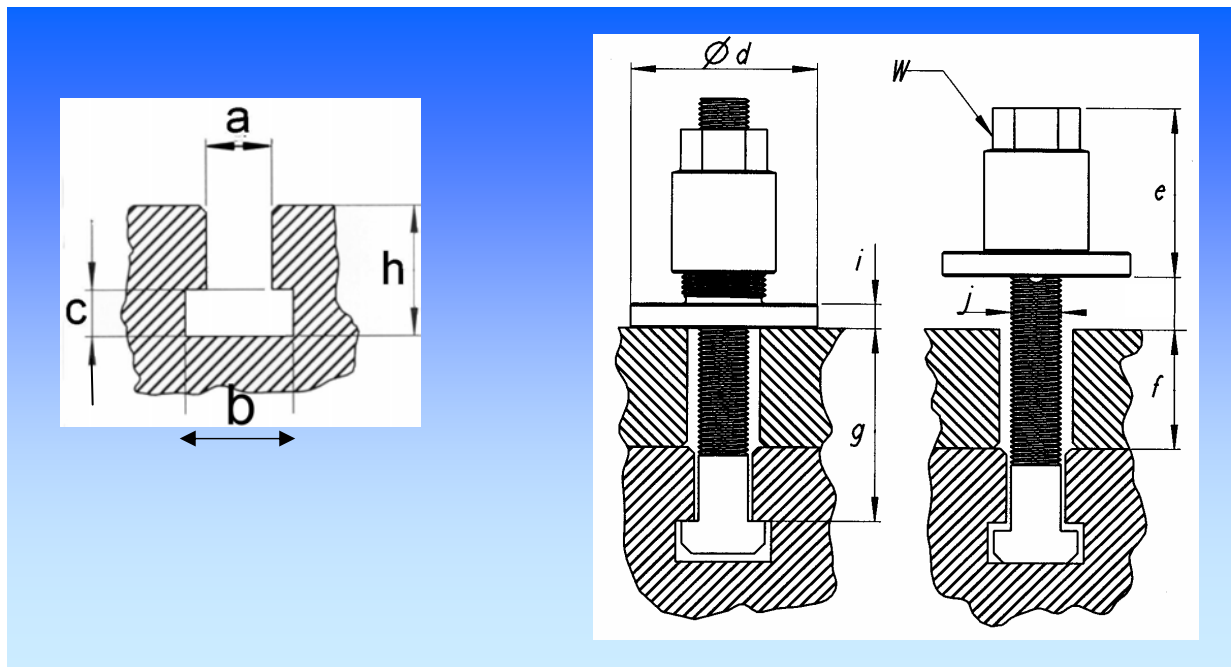

Ange							
Typ	a	b	c	h	f min	f max	antal

Typ	Hållkraft kN	Åt- dragn. Moment Nm	Spänn- omr. mm	d	e	f	g	i	j	Vikt Kg	W Hylsa mm	Spärr- nyckel Art. Nr	Hållare
MC-4-18	40	120	15	40	51	Kundanpassad		8	16	1	24	H4-24	MC4-H
MC-6-22	60	180	20	50	65			10	20	1,5	30	H6-30	MC6-H
MC-8-28	80	240	30	90	82			12	24	2	36	H8-36	MC8-H
MC-10-36	100	300	35	90	85			12	30	2,5	46	H10-46	MC10-H



PDS Automation AB
 Komponentvägen 2
 SE-293 37 OLOFSTRÖM
 Sweden
 Tel: +46 (0)454 480 80

e-mail: info@pdsautomation.se
 Website: www.pdsgroup.se