



OLOFSTRÖM

UNIFEEDER



PRESS AUTOMATION

DESTACKER IDLE STATION

- Simple and solid construction.
- Measure the weight of the panel for recognise eventuality "double part".
- Many year's experience from industrial controllers and press automation contributes to user friendliness and high productivity.

PDS

Functional Principle

The Destacker Idle Station is a device for locate and measure the weight of the panel, if the weight is more than the accepted value it will indicate "double part".

Handling Capability:

Feed direction	min 100 mm max 2500 mm.
Width	min 100 mm. max 4500 mm
Weight. (panel).	max 100 kg.
Weight:	400 kg

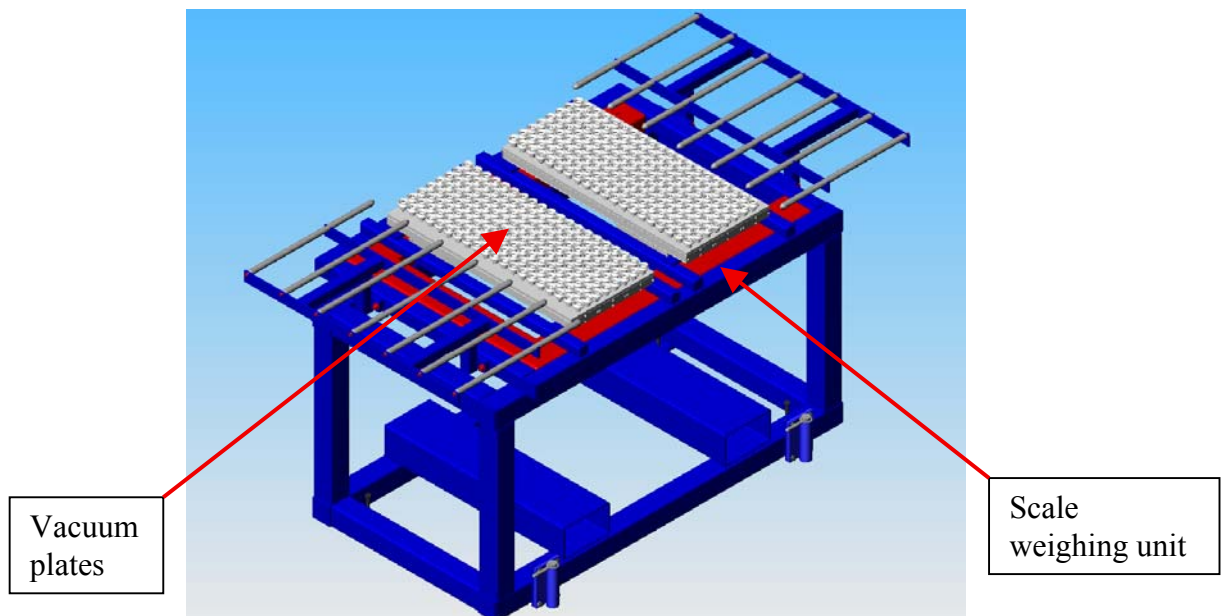

Data for weight of the panel is stored in the control system.

Edition 1.3 eng