

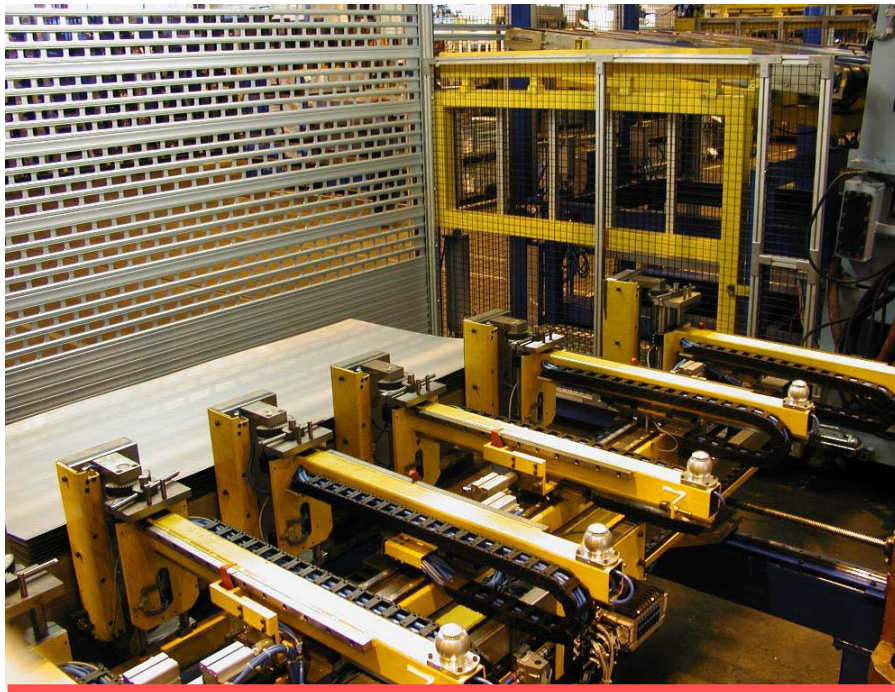

# OLOFSTRÖM

## UNIFEEDER



## PRESS AUTOMATION

### FANNING MAGNET STATION

- Simple and solid construction.
- Both Steel and Aluminium can be separated.
- Many year's experience from industrial controllers and press automation contributes to user friendliness and high productivity.

***PDS***

## Functional Principle

The Fanning Magnet Station is a device for separation of both Steel and Aluminum blanks.

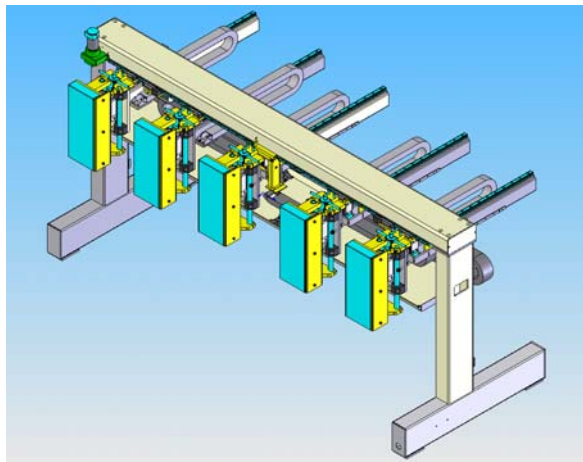
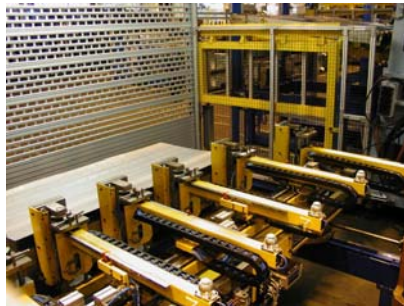

Option: Absolute Encoders for indication of the Fanning magnet position.  
Data is stored in the control system.

Edition 1.4 eng

---

**PDS**

e-mail: [info@pdsautomation.se](mailto:info@pdsautomation.se)  
Website: [www.pdsgroup.se](http://www.pdsgroup.se)

PDS Automation AB  
Komponentvägen 2  
SE-293 37 OLOFSTRÖM  
Sweden

Tel: +46 (0)454 480 80